

Contractor

**H.E. 50/90 EXTERNAL
HE. 100/125 EXTERNAL**

OIL-FIRED CENTRAL HEATING BOILER

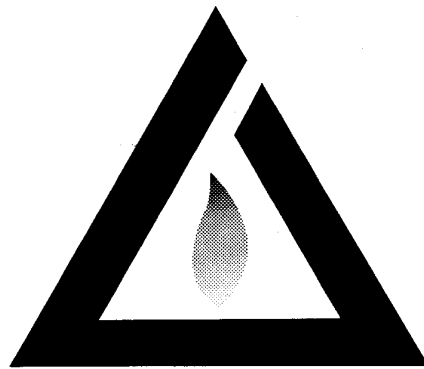

TRIANCO

CE BED 92/42 EEC
EMC 89/336 EEC

**USER, INSTALLATION
COMMISSIONING & SERVICING
INSTRUCTIONS**

To be retained by householder

HEALTH AND SAFETY

INFORMATION FOR THE INSTALLER AND SERVICE ENGINEERS

Under the Consumer Protection Act 1987 and the Health and Safety at Work Act 1974, it is a requirement to provide information on substances hazardous to health (COSHH Regulations 1988).

The Company takes every reasonable care to ensure that these products are designed and constructed to meet these general safety requirements, when properly used and installed.

To fulfil this requirement products are comprehensively tested and examined before despatch.

This appliance may contain some of the items below.

When working on the appliance it is the Users/Engineers responsibility to ensure that any necessary personal protective clothing or equipment is worn appropriate to parts that could be considered as being hazardous to health and safety.

INSULATION AND SEALS

Glass Rope, Mineral Wool, Insulation Pads, Ceramic Fibre, Glass Insulation.

May be harmful if inhaled. May be irritating to the skin, eyes, nose or throat. When handling avoid inhalation and contact with eyes. Use (disposable) gloves, face masks and eye protection.

After handling wash hands and other exposed parts. When disposing, reduce dust with water spray, ensure parts are securely wrapped.

GLUES, SEALANTS & PAINT

Glues, Sealants and Paints are used in the product and present no known hazards when used in the manner for which they are intended.

KEROSENE & GAS OIL FUELS (MINERAL OILS)

1. The effect of mineral oils on the skin vary according to the duration of exposure.
2. The lighter fractions also remove the protective grease normally present on the surface of the skin rendering the skin dry, liable to crack and more prone to damage caused by cuts and abrasions.
3. Skin rashes (oil acne). Seek immediate medical attention for any rash, wart or sore developing on any part of the body, particularly the scrotum.
4. Avoid as far as possible any skin contact with mineral oil or with clothing contaminated with mineral oil.
5. Never breathe any mineral oil vapours. Do not fire the Burner in the open i.e. out of the Boiler as a misfire will cause unburnt oil vapours.
6. Barrier cream containing lanolin such as Rosalex Antisolv, is highly recommended together with a strict routine of personal cleaning.
7. Under no circumstances should mineral oils be taken internally.

CONTENTS

	PAGE NUMBER
1. USER INSTRUCTIONS	4
Introduction	4/5
How to use the boiler	5
After-sales service information	6
2. INTRODUCTION TO INSTALLATION	7
3. TECHNICAL INFORMATION	8
Technical specifications	8/9
4. INSTALLATION	10
Regulations / Health & Safety	10
Siting	10
System design	10
Heating & hot water systems	10
Electrical supply	11
Wiring diagram	11
Condensate drain connections	12
5. OIL SUPPLY	13
Oil	13
Storage tank	13
Single pipe oil supply	14/15
Two pipe oil supply	14/15
Oil de-aerators	14
6. FLUE SYSTEM	16
Installation/Clearances	16
Assembly	17
7. COMMISSIONING	18
8. SERVICING	18/19
9. BURNER FAULT FINDING	20/21
10. SPARES LIST	22

1. USER INSTRUCTIONS

Please note, to assist Trianco in improving customer service, it is important that the guarantee/registration card is returned.

INTRODUCTION

The Trianco Contractor H.E. External boiler has been designed and constructed to give years of trouble-free service and these instructions are provided to assist you in obtaining the best performance with the least trouble and cost.

The boiler will provide both domestic hot water and central heating with the simplest of controls. It is supplied with an adjustable boiler control thermostat, and a manual-reset high limit thermostat, requiring little attention, other than the setting of any system controls (such as a room thermostat or programmer).

TO FIRE THE BOILER

Before firing the boiler, ensure that the system is full of water, that there is a sufficient level of oil in the storage tank, and that all isolation valves are fully open.

Check that the time-switch/programmer (if fitted) is **on** and that the room thermostat is calling for heat.

Set the boiler thermostat (**fig.1**) to the desired temperature.

Switch on the electrical supply to the boiler. The burner should fire after a few seconds.

Set the time-switch/programmer (if fitted) to the times and programme required.

The boiler should now operate automatically, cutting in and out according to the heat demand.

TO STOP THE BOILER

The boiler may be switched off by turning off the boiler control thermostat (**fig.1**) fully anti-clockwise to the **off** position, 'O'.

If the boiler is to be off for a long period of time, it is recommended that the mains supply to the appliance is switched off, or the time-switch/programmer (if fitted) is set to the **OFF** position.

BOILER CONTROL THERMOSTAT

The boiler control thermostat allows you to select the temperature of the water leaving the boiler. It is calibrated between High and Low, in five intermediate settings, corresponding to a temperature range between 82°C (High) and 55°C (Low). The thermostat is switched off when the knob is turned fully anti-clockwise to position 'O'.

Note: Where a cylinder thermostat or room thermostat is fitted, ensure that the boiler thermostat is set above or equal to the highest setting. satisfied

HIGH-LIMIT THERMOSTAT

The high-limit thermostat is factory-set and requires no adjustment. Should the boiler thermostat malfunction and the water temperature rise to 110°C, the limit thermostat will take over and shut down the appliance.

The limit thermostat is located on the rear of the control box and can be reset by pushing in the button. If the thermostat operates frequently, consult your service engineer, as there may be a fault in the system.

Note: the high-limit thermostat can only be reset when the water temperature has dropped by at least 20°C.

BURNER LOCK-OUT

If the burner fails to light for any reason, the boiler will go into lock-out mode, indicated by the illumination of the reset button on the burner control box (**fig. 2**). To reset the burner, press this button. If the burner returns to lock-out, wait for one minute before pressing the button again.

If the burner still fails to light, follow the simple fault-finding guide (**page 5**), before switching off the electrical supply to the boiler and contacting your service engineer if the failure persists.

Important: do not attempt to reset the burner more than twice – constant attempts to do so may cause permanent damage to components within the burner.

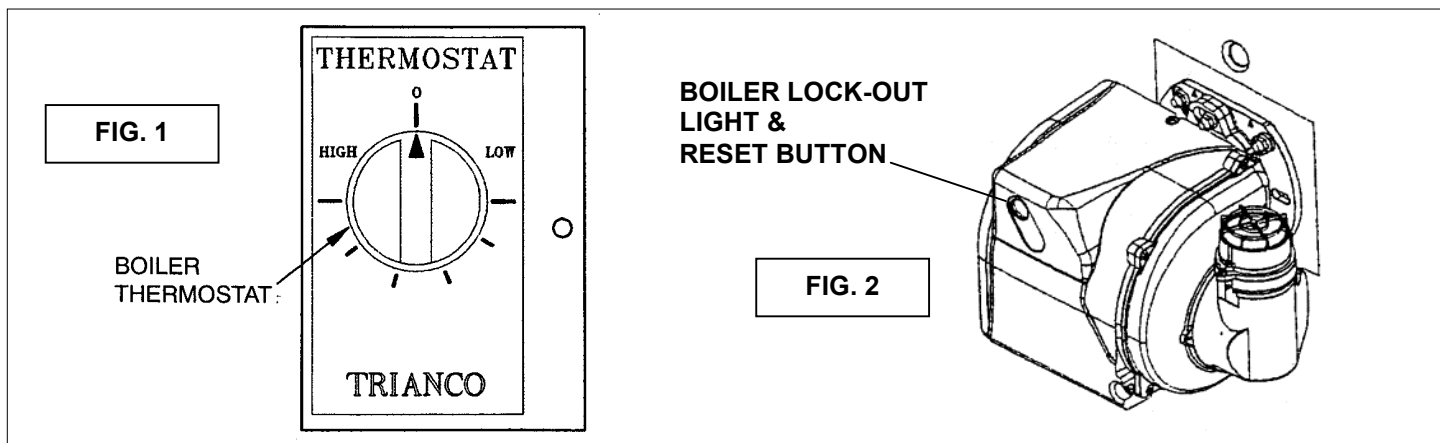

SYSTEM CONTROLS

ROOM THERMOSTAT

The room thermostat should not be positioned near a source of heat, such as a radiator, or be exposed to direct sunlight, as this will cause the heating to switch off before the room is up to the correct required temperature. Always follow the manufacturer's instructions for the best siting position of the room thermostat.

TIME-SWITCH/PROGRAMMER

When choosing the operating times for your boiler, it is useful to remember that central heating systems usually take between half an hour and an hour before becoming effective and usually remain warm for up to half an hour after boiler shut-down. The timer can therefore be switched off earlier as an economy measure.

FROST PROTECTION

As the boiler will be sited externally to the property being heated, the water may be in danger of freezing and, as such, the appliance is protected by a factory-fitted frost thermostat, which will cause the boiler to fire should the temperature within the casings drop to below 7°C).

If the system is shut down for a long period during very cold weather, it is also advisable to completely drain the system. However, too frequent draining of the system should be avoided, especially in hard water areas, as this could lead to scaling of the boiler waterways.

See **page 7** for flushing and water treatment.

SHUTTING DOWN FOR THE SUMMER

If the boiler is shut down for the summer months, it is advisable to have it serviced and thoroughly cleaned as soon as possible to minimise corrosion of the heating surfaces.

OIL

The oil for your boiler is 28 sec. Kerosene class C2 to BS 2869.

Always ensure that the oil storage tank is topped up regularly; do not wait until the tank is nearly empty before refilling, as sludge and water could be sucked into the oil pipe, affecting the operation of the burner and potentially reducing the life of the pump.

After a delivery of oil, it is recommended that it be allowed to settle in the tank for about half an hour before restarting the boiler.

Sludge and water caused by condensation should be drawn off at the drain-cock on the oil tank annually.

SIMPLE FAULT-FINDING

If the boiler fails to start for no apparent reason, carry out the following checks before calling your service engineer:

1. Check for failure in the electrical supply.
2. Check for a blown fuse. If the fuse has blown and the replacement subsequently blows again, switch off the mains electrical supply to the boiler and contact your service engineer.
3. Check that there is adequate oil in the tank and that all isolation valves are fully open.
4. Check for burner lock-out (see **page 4**).
5. Check for excess water temperature (see high-limit thermostat details, **page 4**, for further details).

Note: If the boiler has been shut down due to a failure of the power supply, it may be necessary to reset the time-switch or programmer to the correct time, unless the device has an in-built power reserve.

SERVICING

To ensure the efficient and reliable operation of the boiler it is essential that the burner be **commissioned** immediately after installation, and prior to first use. The boiler requires an annual service thereafter.

IMPORTANT NOTES

1. Only an OFTEC-trained and registered engineer can carry out commissioning and service work.
2. Electrical safety checks should be carried out by a qualified electrical engineer.
3. It is the responsibility of the installer to ensure proper commissioning is carried out.
4. It is a requirement of the guarantee and any extended warranty that an annual service is carried out.
5. The system water must always be protected by a corrosion inhibitor.

TRIANCO

CUSTOMER AFTER SALES SERVICE INFORMATION

A step by step guide to reporting a fault with your appliance

A qualified field SERVICE ENGINEER is available to attend a breakdown or manufacturing fault occurring whilst the appliance is under guarantee.

The appliance must be made available for service during normal working hours, Monday to Friday (no weekend work is accepted).

A charge will be made where:

- Our Field Service Engineer finds no fault with the appliance
or
- The cause of a breakdown is due to other parts of the plumbing/heating system (including oil line/lack of oil), or with equipment not supplied by Trianco.
or
- Where the appliance falls outside the guarantee period (see terms and conditions enclosed).
or
- The appliance has not been correctly installed, commissioned or serviced as recommended (see commissioning, installation and servicing instructions)
or
- The breakdown occurs immediately following an annual service visit. In this instance your appointed Service Agent must check all his work PRIOR to requesting Trianco to attend.

PLEASE NOTE:

Unauthorised invoices for attendance and repair work carried out on this appliance by any third party will not be accepted by Trianco.

NOTE: Burner nozzles are currently guaranteed until the first service.

Over 50% of all service calls made are found to have no appliance fault.

What to do in the event of an appliance fault or breakdown:

Step 1: Always contact your installer or commissioning engineer in the first instance, who must thoroughly check all his work PRIOR to requesting a service visit from Trianco.

Step 2: If your appliance has developed an in-guarantee fault your installer should contact Trianco Service Centre for assistance.

What happens if my installer/engineer is unavailable?

Step 3: Contact Trianco Direct. We will provide you with the name and telephone number of our Service Agent. However, a charge will apply if the fault is not covered by the appliance guarantee (payment will be requested on site by our independent Service Agent).

Note: Before contacting Trianco, please have the following information ready:

- 1) Boiler serial number or your customer ID number (issued upon registration of the boiler with Trianco).
- 2) Date of appliance installation.

Boiler Serial No.:	_____
Cust. ID No.:	_____
Installation Date:	__/__/__

SERVICE CENTRE AND TECHNICAL SUPPORT

Tel: 0114 257 2300 Fax: 0114 257 2338

Hours of business Monday to Thursday 8.30am - 5:00pm

Friday 8.30am - 2.30pm

INSTALLATION INSTRUCTIONS

2. INTRODUCTION

The Contractor H.E. External boiler has been designed to conform to European Directive/Standards BED 92/42 EEC LVD 73/23/EEC EMC 89/336/EEC.

The boiler design incorporates a secondary stainless steel heat exchanger, which recovers heat from the flue gases which would normally be lost when using conventional oil-fired boilers.

The matched pressure-jet burner is exceptionally quiet in operation and ensures clean and efficient combustion, with low NOx emissions.

The boiler is suitable for all normal open-vented central heating and indirect hot water systems. The boiler can also be used with sealed systems up to a working pressure of 3 bar, with the appropriate sealed system safety equipment.

One return and two flow sockets are provided to facilitate connection to the heating and hot water systems.

To ensure that the boiler is operating at maximum efficiency, the central heating return temperature should be 50°C or above. Maximum performance will be achieved by maintaining a differential of 20°-30°C between the flow and return water temperatures.

Due to the high efficiency of this range of boilers, and to comply with Building Regulations, Part L, it is essential that the appliance be fitted on fully-pumped systems only.

All servicing can be carried out from the front of the boiler. The front-mounted flue-cover permits easy access for removal of the baffles and cleaning of heating surfaces.

The boiler is fully automatic in operation and incorporates all necessary safety controls to ensure safe and reliable running.

The Contractor H.E. External boiler is supplied with the burner set for 28 sec. Kerosene Class C2 to BS 2869 fuel to meet the Building Regulation requirements for low-level flue discharge.

FLUSHING AND WATER TREATMENT

The performance of the appliance could be impaired by system debris or the effects of corrosion. New systems must be thoroughly flushed to remove metal filings, solder, machining oils and any other fluxes or greases before connecting the boiler.

When fitting the appliance to an existing system, it is advisable to clean the system by using an appropriate flushing and descaling agent. Refer to BS 7593 [1992] for guidance.

System additives - corrosion inhibitors and all flushing agents/descalers should be suitable for steel boilers and comply with BS 7593 requirements.

Always refer to manufacturers' instructions.

Failure to flush and add inhibitors to the system will invalidate the appliance warranty.

The appliance is designed to be fitted to fully-pumped systems only. Failure to do so will invalidate the warranty.

The boiler must not be run without water in the system.

IMPORTANT NOTICE:

To comply with regulations in force, the boiler must be installed and commissioned by an OFTEC-registered engineer. The installation must comply with all requirements of current *Building Regulations, Part L.*

Failure to meet the terms of these requirements may invalidate the guarantee.

THE PERSON(S) WHO INSTALLS THIS APPLIANCE, SERVICES OF CARRIES OUT ANY REMEDIAL WORK, i.e. ELECTRICAL FAULT-FINDING, MUST HAVE THE SUITABLE ENGINEERING QUALIFICATIONS.

3. TECHNICAL INFORMATION

	50/90	100/125
A	1005	1042
B	500	506
C	746	808
D	980	1042
E	180	176
F	854	900
G	138	138
H	74	74
J	608	652
K	693	737
L	250	260
M	42	39
N	694	737
P	734	740

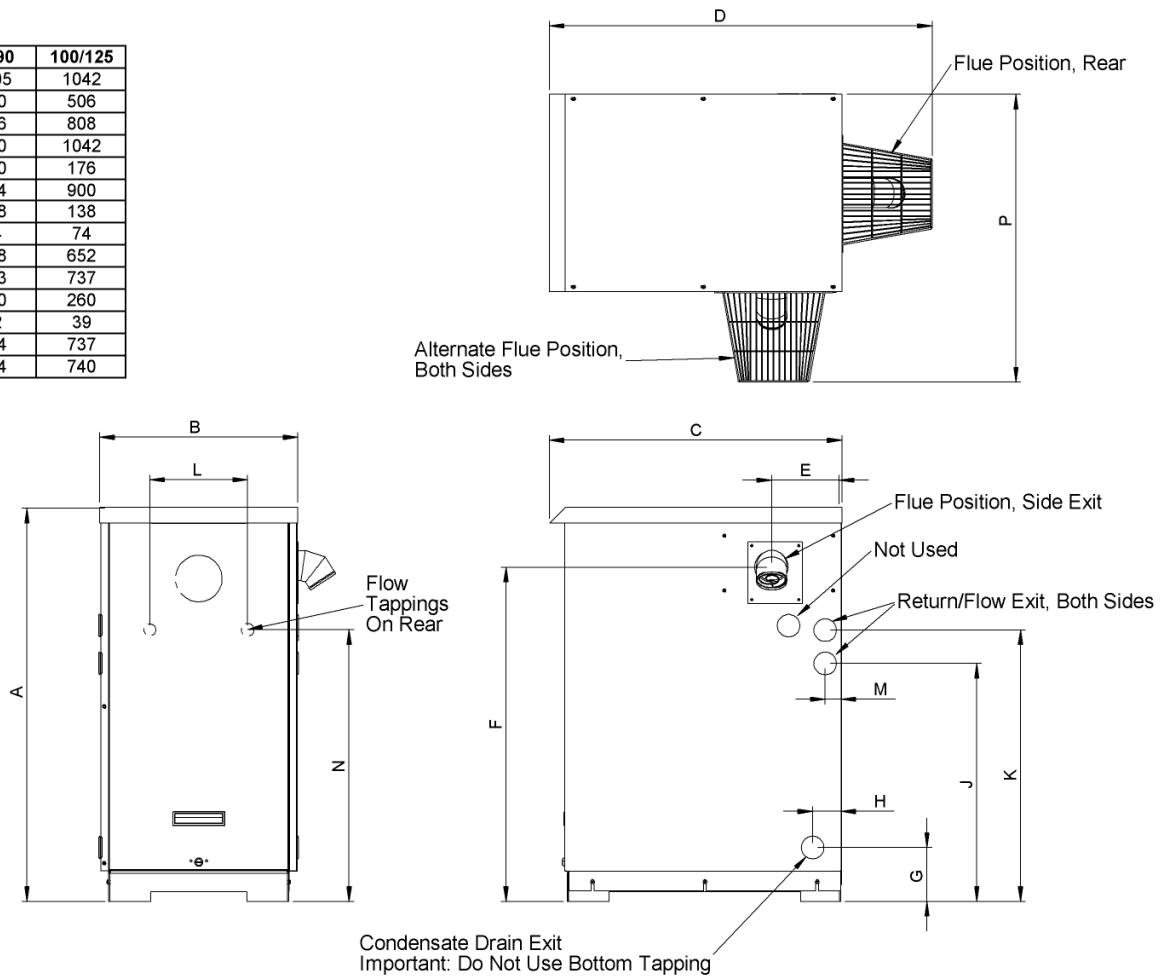

FIG. 3 OUTLINE DIMENSIONS

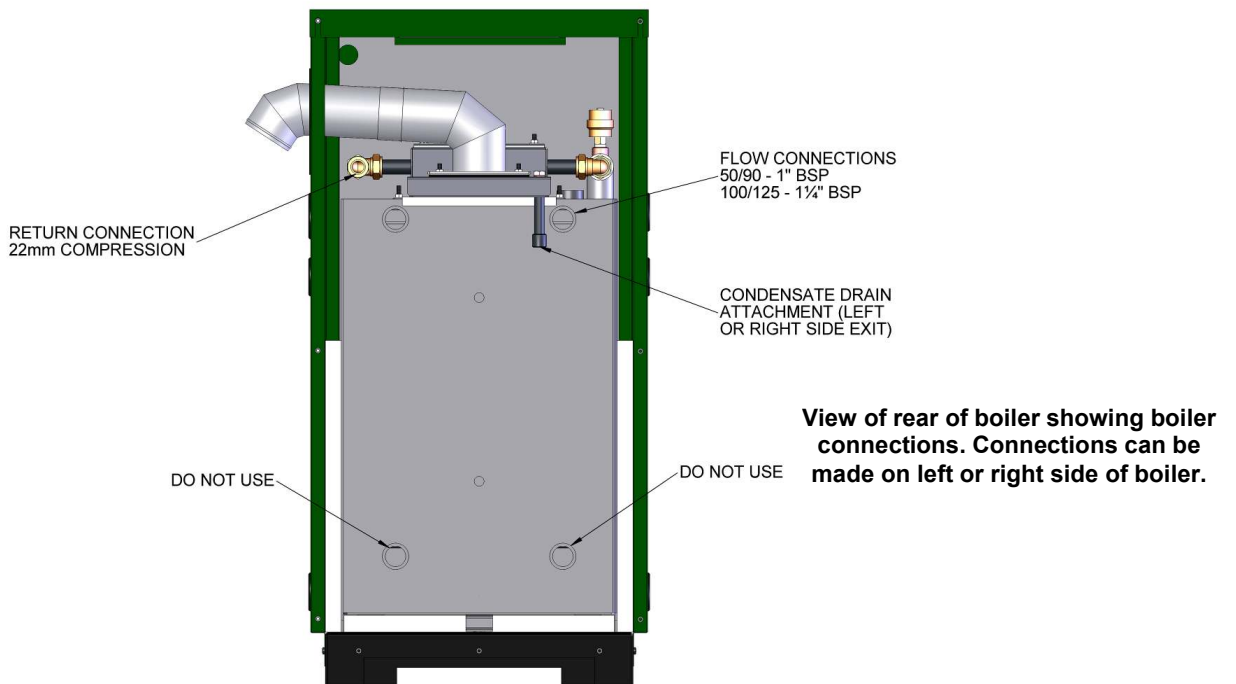

FIG. 4

TECHNICAL SPECIFICATION

	50/90	100/125
WEIGHT	140kg	170kg
WATER CONTENT	25 litres	32 litres
FLOW CONNECTIONS	1" BSP	1¼" BSP
RETURN CONNECTION	22mm Compression	
MAX OPERATING PRESSURE	3 bar (43.5 psi)	
TEST PRESSURE	4.5 bar (65.3 psi)	
STARTING CURRENT	3.5 amp	
RUNNING CURRENT	0.77 amp	
CONTROL THERMOSTAT	Adjustable up to 82°C	
LIMIT THERMOSTAT	Factory-set at 110°C	
FROST THERMOSTAT	Factory-set at 7°C	
CASING FINISH	Galvanised Steel, Painted Green	
THERMAL INSULATION	Boiler shell insulated with glass fibre	
ELECTRICITY SUPPLY	230/280V – 50Hz fused at 5 amp	

BURNER INFORMATION

Model	Output (non-condensing)	Output (condensing)	Input	Nozzle	Pump Pressure	CO₂ (%)
Contractor H.E. 50/90	50,000 BTUs	51,272	53,022	0.45 x 80°EH	120 psi	11.5
	60,000 BTUs	61,526	63,626	0.5 x 80°EH	140 psi	11.5
	70,000 BTUs	71,781	74,231	0.65 x 80°S	140 psi	11.0
	80,000 BTUs	82,649	85,470	0.75 x 80°EH	130 psi	11.5
	90,000 BTUs	92,980	96,154	0.85 x 80°S	105 psi	11.5
Contractor H.E. 100/125	100,000 BTUs	102,360	109,866	1.0 x 80°EH	96 psi	11.8
	112,500 BTUs	115,326	120,102	1.1 x 80°EH	104 psi	12.6
	125,000 BTUs	129,656	132,726	1.1 x 80°EH	120 psi	12.3

4. INSTALLATION

REGULATIONS

Installation of the boiler must comply with the following British Standards and Regulations:

BS 5410: Part 1 – Code of Practice for Oil-Firing.

BS 5449 – Forced Circulation Hot Water Central Heating Systems.

Building Regulations - Part J (England and Wales)
 - Part F sect. 111 (Scotland)
 - Part L

The Control of Pollution (Oil) Regulations
Current I.E.E. Regulations
Local Water Undertakings Bylaws
OFTEC Installation Requirements for Oil-Fired Boilers and
Oil Storage Tanks, OFST 100 & OFST 200.

HEALTH AND SAFETY AT WORK ACT

The installer should be aware of his responsibilities under the Act and provide, where necessary, appropriate protection for all persons carrying out the installation.

In the interests of safety, it is required that the appliance is installed, commissioned and serviced by and OFTEC registered technician.

A guide to safe working practices for oil-firing technicians is available from OFTEC.

Electrical work should be carried out in accordance with BS 7671:2001 by a qualified electrical engineer.

SITING THE BOILER

Sound Levels

Whilst the low sound level of the boiler makes it suitable for utility room installation, the following factors should be taken into consideration before installation:

- (a) Some people are particularly sensitive to low noise levels – discuss with the householder.
- (b) Low-level flue terminals produce some exhaust noise, so care should be taken when siting adjacent to neighbouring property, patios and play areas.
- (c) Due to the condensing nature of the boiler, a plume of water vapour will be discharged from the flue. This should be taken into account when siting the flue terminal. Refer to section on flue systems.

Clearance and Service Access

When siting the boiler, ensure adequate clearance is allowed for making water and flue connections. As the boiler can be fully serviced from the front, there is no need for headroom allowance. However, a clearance of at least 750mm is required at the front of the boiler for future service access.

Hearth

The boiler must be fitted on a non-combustible base, which is level and capable of supporting the installed weight of the boiler, including its full water content. The base should be above ground level to prevent water damage.

SYSTEM DESIGN

To achieve the maximum system efficiencies, the heating system should be designed to the following parameters:

Boiler Flow Temperature - 50°C to 80°C
Flow Differential Temperature - 10°C to 30°C

COMBUSTION AND VENTILATION AIR

The provision of an adequate supply of combustion air is essential for the efficient and safe operation of the boiler. The combustion air inlet is located at the top of the front door of the appliance. Under no circumstances should this be covered or blocked.

HEATING AND DOMESTIC HOT WATER SYSTEMS

The heating system should be installed in accordance with current HVCA Codes of Practice and BS 5449 Part 1 – Forced Circulation Hot Water Central Heating Systems.

The flow water connections can be made to the boiler by using the tappings on the left or right hand side of the boiler. The return is made via the connection on the secondary heat exchanger.

All exposed pipework connecting the boiler to the heating system **must** be lagged.

A drain-off cock should be fitted in the lowest part of the system.

Where the boiler is also used for providing domestic hot water, a double-feed indirect cylinder to BS 1566 Part 1 must be used.

Flush out the system to remove any residue before fitting the circulating pump.

Make sure all unused boiler tappings are plugged before filling the system.

ELECTRICAL SUPPLY

230V single-phase 50Hz (fused 5 amp)

Note: this appliance must be earthed and the electrical supply cable must be of a greater length than the current-carrying conductor cables (i.e. live and neutral supply cables).

All electrical wiring must be carried out by a qualified electrician, in accordance with current I.E.E. Regulations and any local regulations which may apply.

The 230V – 50Hz electrical supply must be fused by a double-pole switch, with a contact separation of at least 3mm in both poles, and by a shuttered socket adjacent to the boiler (both devices must meet the requirements of BS 1363).

The minimum requirement for the power supply cable is PVC sheathed flexible cord, 0.75mm² (24x0.2mm, code designation H05 VV-F or H05 VVH2-F), as specified in table 16 of BD 6500.

All external cables entering the control box must be secured in position by the use of strain-relief bushes (supplied, see **fig. 7** for fitting instructions).

Terminal connections are also provided in the control box for the ancillary controls.

It is strongly recommended that an RCD is fitted in the boiler supply circuit.

See wiring diagram, **Fig. 8** for further details.

High and Low Voltage Warning

In certain areas of the country, where there is a known risk of high or low voltage fluctuations, the burner should be prevented from starting by the use of a voltage-sensitive device if the voltage drops or increases sufficiently to endanger the installation.

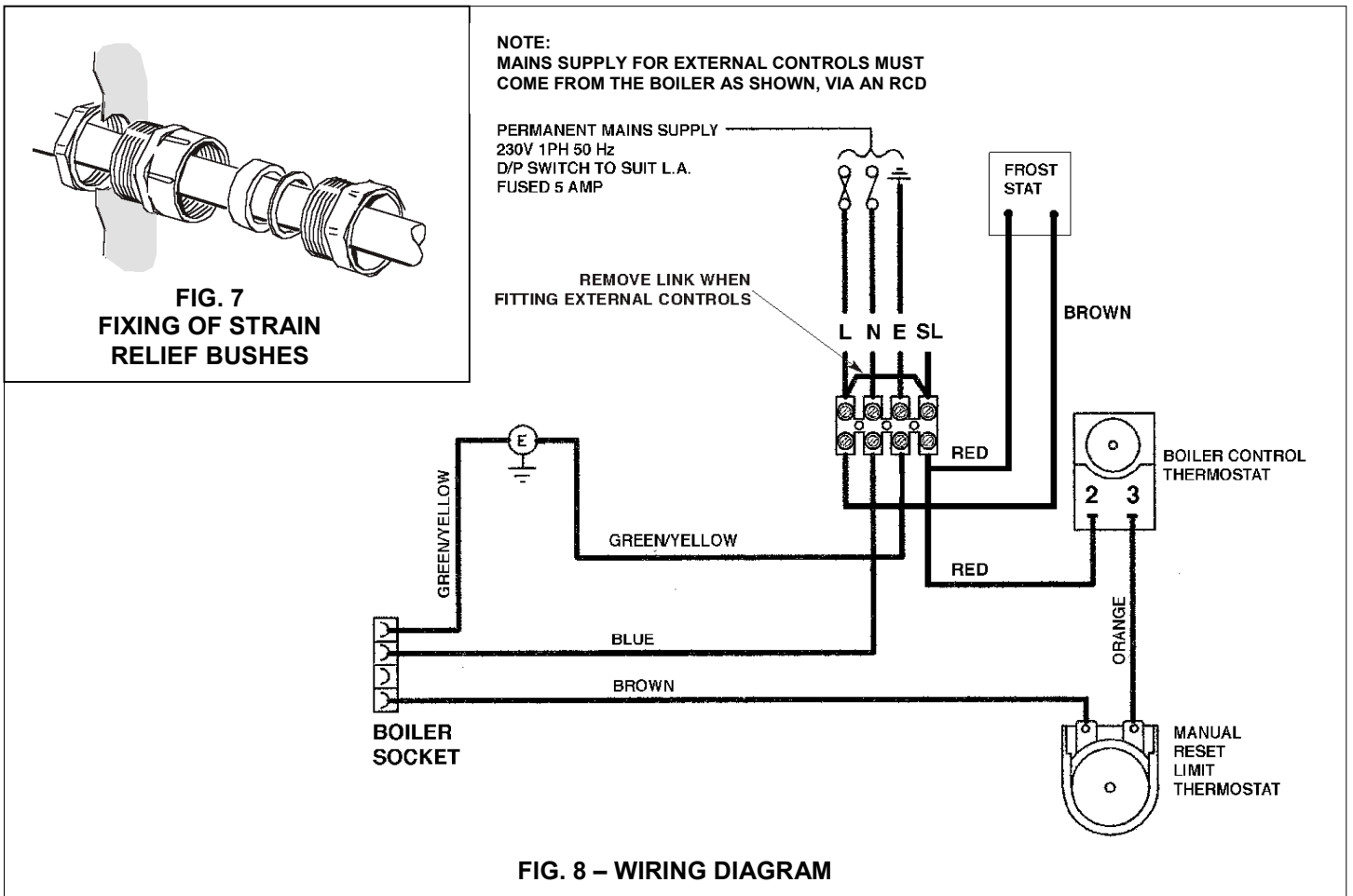

CONDENSATE DRAIN CONNECTIONS

The condensate pipe can be run to either the left or the right side of the boiler and for ease of installation should be fitted before the boiler is positioned. Remove the boiler back casing before installing the condensate pipework.

To install the condensate pipe, after deciding the direction in which it should run, feed the long end through the side casing from the inside. Attach the short end (with the connecting nut) to the drain connector on the back of the condensing unit, ensuring a watertight seal is made.

Where possible, connect the condensate pipework to an external waste drain.

The drain pipe must be installed to allow the condensate to drain naturally from the boiler, on a minimum fall of 1:20.

The drain from the boiler must be 22mm diameter pipework.

The pipework from the condensate trap to the external drain is not supplied with the boiler.

Upon successful installation of the condensate pipework, remove the inspection cover from the top of the condensing unit and pour a small amount of water inside. Examine the condensate pipework for any resultant leaks and rectify accordingly.

Failure to fill the trap with water before firing the boiler may result in damage to the drainage pipework and potentially allow the escape of flue gases. Any damage caused as a result of not filling the trap will not be covered by the appliance guarantee.

This process will also leave water inside the 'U' section of the condensate pipework, creating a seal to stop the escape of flue gases.

Failure to carry out this procedure will result in damage to the boiler and invalidate the appliance warranty.

IMPORTANT NOTES:

When running any external pipework from the trap to the drain, it is essential that the pipework is kept to a minimum and is insulated to prevent the condensate from freezing.

MAINTENANCE:

The trap should be inspected at regular intervals to ensure correct operation, and should be checked as part of the annual service schedule.

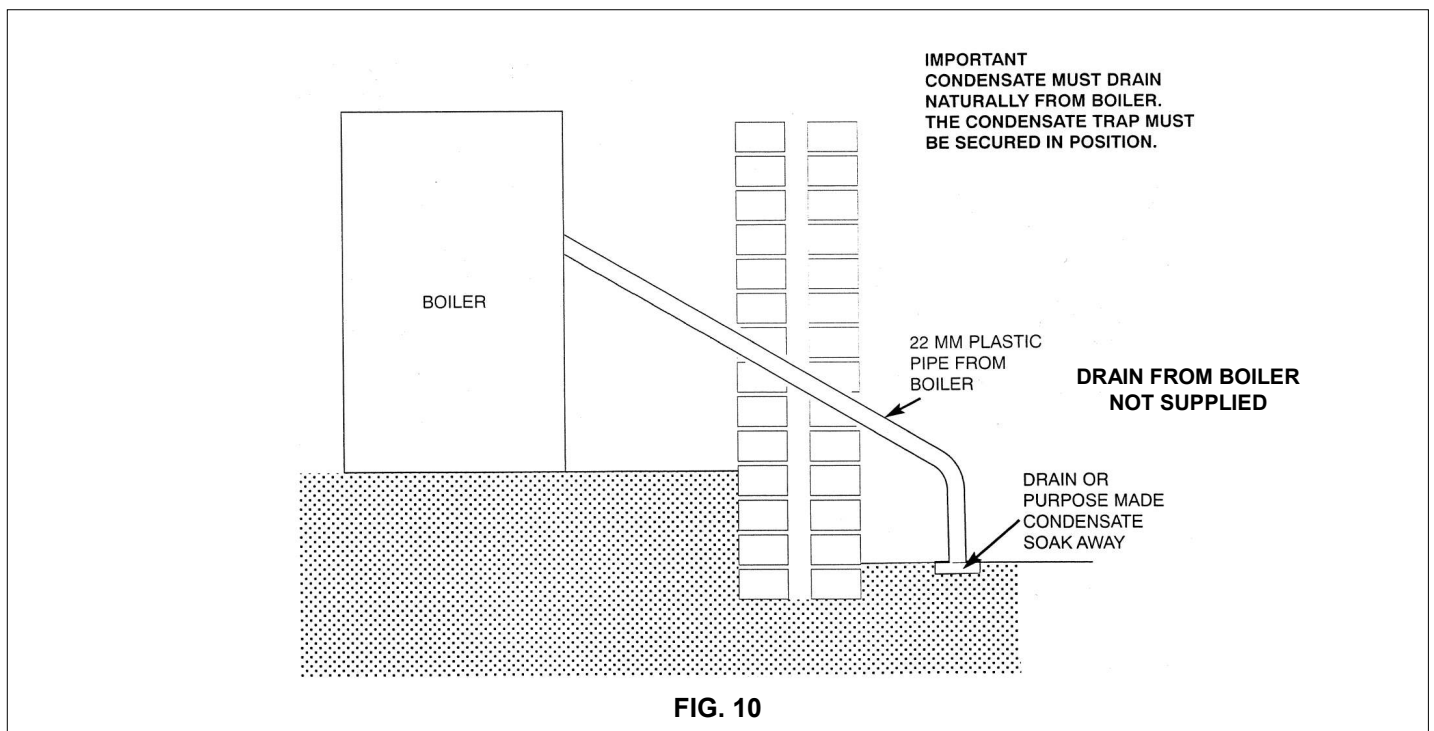
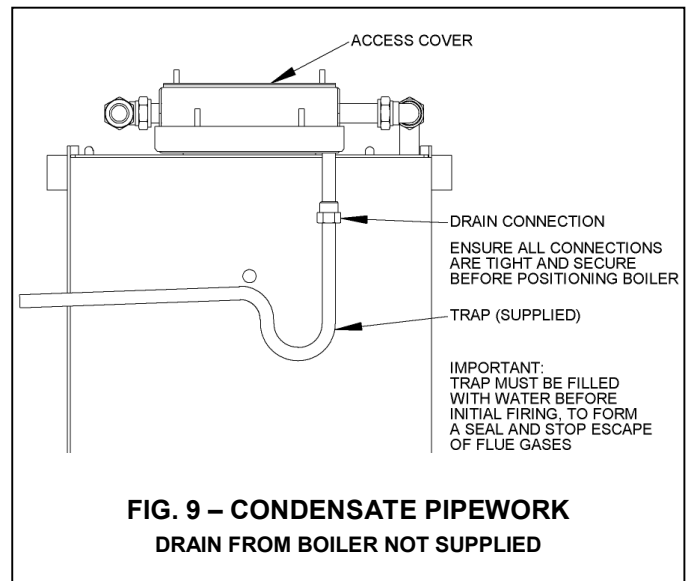

5. OIL SUPPLY

OIL

The burner is factory-set to burn 28 sec. Kerosene Class C2 to BS 2869.

Trianco makes no guarantee as to the satisfactory operation of the boiler using fuels other than that which is stated above.

STORAGE TANK

The tank should be fitted with weather-protected fill and vent connections, a drain-off cock, and an oil level indicator.

Size and Location of Tank

The tank should be large enough to allow for economic deliveries and be located in an unobtrusive position, having regard to the need for safety, filling, maintenance, and head of oil required (see **Fig. 11**).

Steel Tanks

Steel tanks must comply with the requirements of BS 799 Part 5: 1987 and should be mounted on brick or block piers, with a waterproof membrane fitted between the piers and tank.

Plastic Tanks

Polyethylene tanks may be used, having several advantages over traditional steel tanks:

- (a) Pier supports are not required; the tank may be fitted directly onto a flat surface.
- (b) They do not corrode; therefore never require repainting.
- (c) They are easier to handle because of lower weight.
- (d) They are supplied with a 10-year manufacturer's guarantee.

Fire Protection

Whilst it is highly unlikely that a fire could start from a domestic oil tank, protection is required from a fire which may originate elsewhere. The tank should be at least 1.8 metres from a building and 750mm from a site boundary. Where it is not feasible to adhere to these limits, the building wall must not have any openings other than those for ventilation, the wall must have at least a half-hour resistance to fire, and must extend 1.8 metres from any part of the tank.

Alternatively, a non-combustible radiation barrier can be employed, which meets all the requirements of BS 5410 Part 1. This standard applies to tanks up to a capacity of 3,500 litres.

See current OFTEC regulations for further details.

To comply with Building Regulations, **section J5**:

1. Where the tank is close to a dwelling, fire protection must be provided to the eaves, if less than 1.8 metres from the top of the tank.
2. Cladding must extend at least 300mm beyond the tank.
3. The tank must be fitted on a non-combustible base.

Pollution Protection

To comply with Building Regulations, **section J6**, the tank must be bunded (double-walled) if:

1. The tank is less than 10m from a stream
2. The tank is less than 50m from a well, spring, or other source of drinking water.
3. The tank cannot be viewed from the point of delivery.
4. There is risk of oil reaching a manhole cover or drain in the event of a leak.
5. The tank capacity exceeds 2,500 litres.

SUPPLY

A long-life flexible oil hose is supplied with the boiler. A filter and shut-off valve are also required. These should be fitted as shown on **Figs. 11, 12, & 13**.

All oil line joints must be completely sealed and the total pipe run should be flushed thoroughly before connection is made to the burner. No soldered joints are permitted in the oil line.

Fire Valve

A remote-operated fire valve must be fitted in the oil supply line, externally to the premises, with the sensing phial located at a point above the burner.

To comply with OFTEC regulations, a CD/10 form must be completed and left with the appliance upon installation.

OIL SUPPLY (cont.)

Single-Pipe Oil Supply (Fig. 12)

Where the lowermost part of the tank is above the level of the burner, a single-pipe gravity system can be used. The oil supply pipe should be connected to the suction port on the burner pump via the flexible hose supplied.

Two-Pipe Oil Supply (Fig. 13)

Where the lowermost part of the tank is below the level of the burner, a two-pipe suction lift is necessary.

When using the two-pipe system, it is important to convert the suction pump on the burner to operate as such: remove the end cover and filter, then remove the bottom screw and the 'U' washer. Replace the screw, making sure it is fully inserted. See the burner details leaflet for further information.

A spring-loaded non-return valve must be fitted in the suction line to prevent the oil running back to the tank. No valves are permitted in the return line.

An additional flexible oil line is also required.

Notes:

1. The pump suction should not exceed 0.4bar, as dissolved gas may be released from the oil, affecting combustion.
2. The return pipe must end at the same level as the suction outlet to prevent loss of prime.
3. The outlet from the tank should be approximately 75mm (3") above the bottom to prevent sediment and water being drawn into the supply line.

Single-Pipe Oil Supply with De-aerator (Fig. 11)

Where a two-pipe suction lift is required, but the return pipe requirement is too long, or impractical to run, an oil de-aerator can be used. The burner should be piped as for a two-pipe system, up until the de-aerator, when a single pipe can be taken the remaining distance to the storage tank. The de-aerator should be fitted at the closest point to the boiler, externally to the premises.

A non-return valve is not required with this system, but the 'U' washer must be removed in the same manner as a standard two-pipe system.

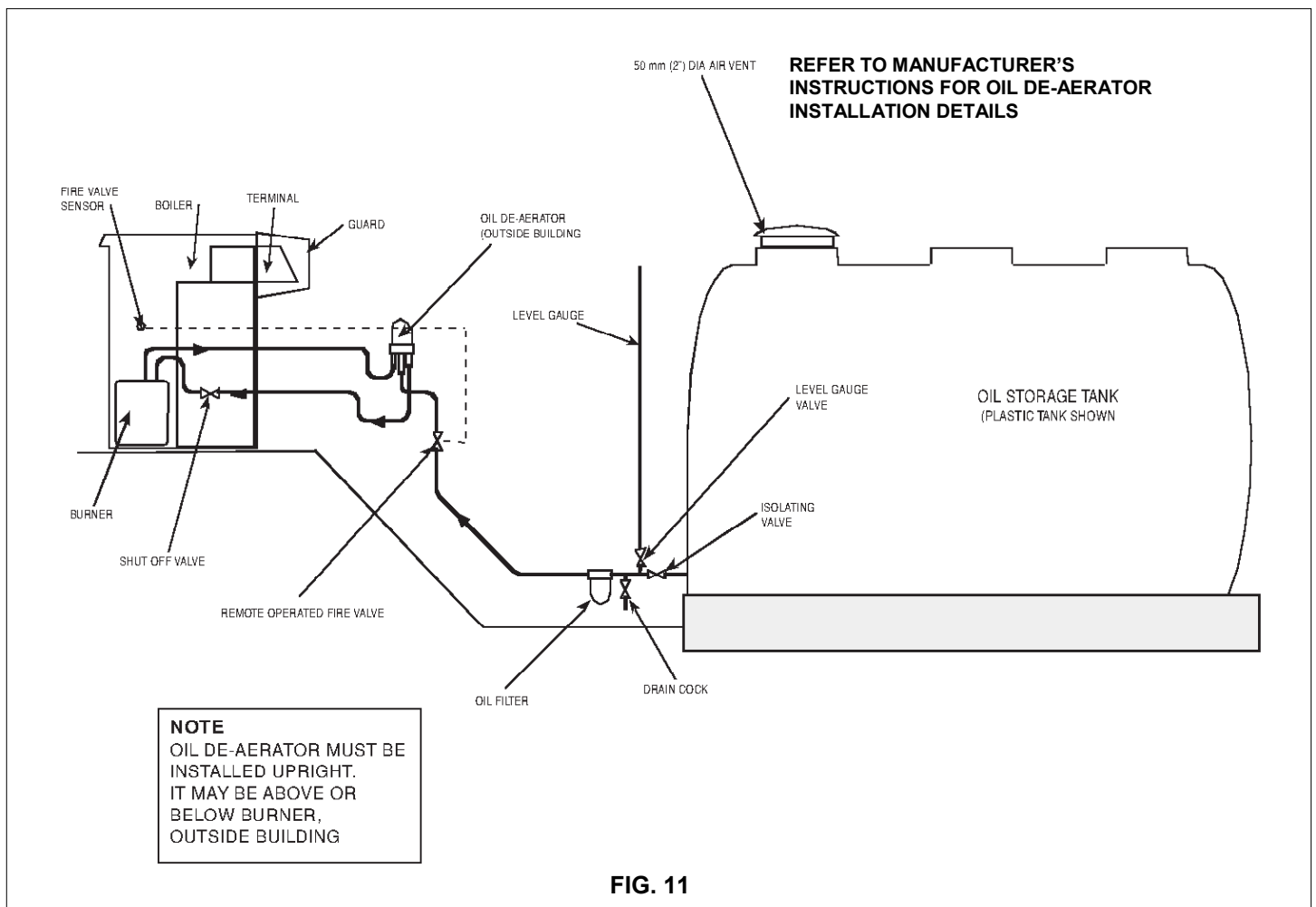

MAXIMUM OIL SUPPLY LINE LENGTH 'L'

HEAD 'H' METRES.		.0.5	1.0	1.5	2.0	2.5	3.0	3.5	4.0
PIPE 6mm ID	MAXIMUM LENGTH (METRES)	10	21	31	41	52	62	73	83
PIPE 8mm ID		33	66	98	100	100	100	100	100

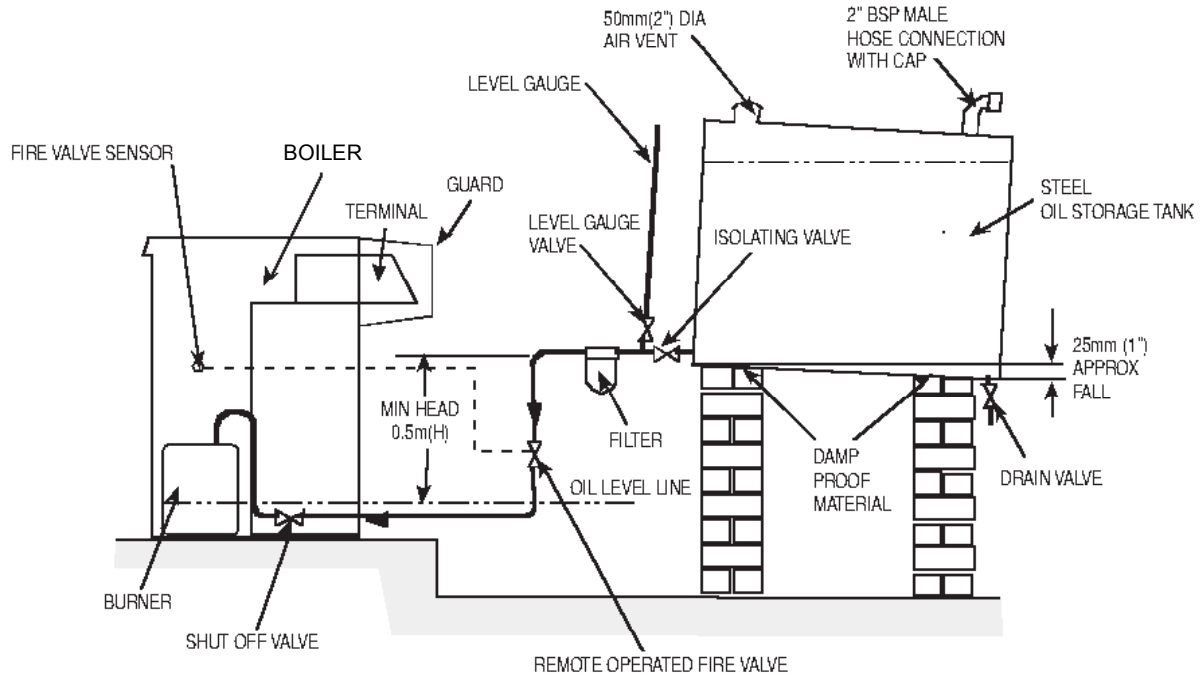

FIG. 12 – SINGLE-PIPE OIL SUPPLY

MAXIMUM OIL SUPPLY LINE LENGTH 'L'

LIFT 'L' METRES.		.0.5	1.0	1.5	2.0	2.5	3.0	3.5	4.0
PIPE 6mm ID	MAXIMUM LENGTH (METRES)	48	42	36	30	24	18	11	5
PIPE 8mm ID		100	100	100	94	75	55	36	16
PIPE 10MM ID		100	100	100	100	100	100	88	40

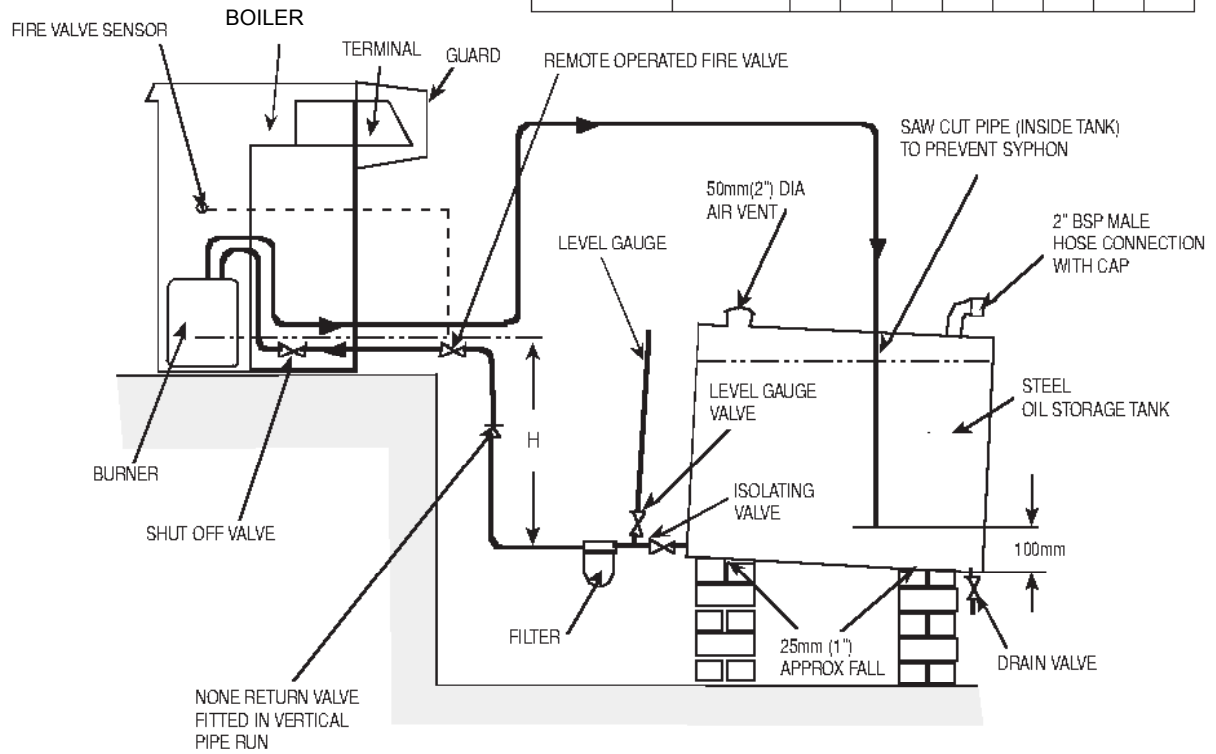

FIG. 13 – TWO-PIPE OIL SUPPLY

6. FLUE DISCHARGE

To evacuate the products of combustion safely and thoroughly, the boiler has a highly efficient integral flue system and there is no need to fit the boiler to a separate flue. See page 17 for flue fitting instructions.

INSTALLATION NOTES

- a) Trianco H.E. boilers operate at high efficiencies with low flue gas temperatures. The flue system used on this boiler is suitable for low flue gas temperatures and condensation.
- b) Ensure that all the joints on the flue system are adequately sealed, and that no condensation can escape. It may be necessary to apply a thin bead of silicone sealant or other lubricating substance around the flue joints and 'o'-ring seals before assembling the flue.
- c) Only 28 sec. Kerosene class C2 to BS 2869 is permitted for boilers using low-level flue discharge.
- d) Positioning of flues under balconies and carports is to be avoided
- e) Modern low-level flue boilers are designed to operate at low noise levels. However, when positioning you boiler, it is not recommended to have the terminal facing a neighbour's property or patio, etc.
- f) The boiler should also be positioned to avoid the products of combustion entering the building. A distance of at least 600mm must be allowed between the terminal and any window, door or other opening into the building (see **fig. 14**) for recommended terminal positions.
- g) At certain times during operation, a plume of condensation will be produced from the terminal. When positioning the boiler, this should be taken into consideration to ensure that it does not cause a nuisance to neighbouring properties.
- h) Keep the terminal clear of infra-red sensing devices, such as those used to control security lighting.
- i) The terminal must be protected by the guard supplied.

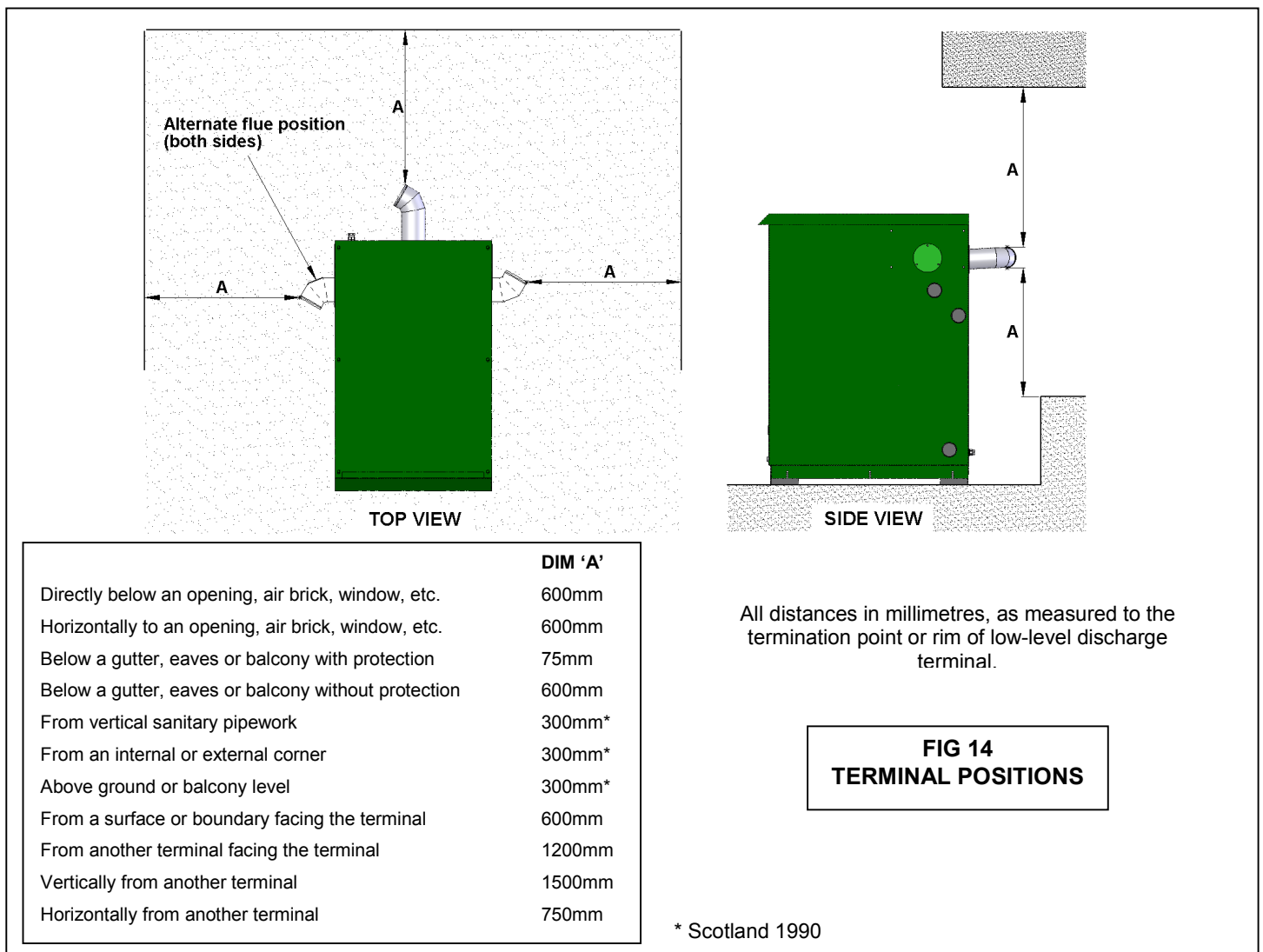

FLUE ASSEMBLY

The flue terminal pack (supplied) should contain the following items. Check all components are present before fitting:

- 1 x Flue Terminal Assembly
- 1 x Elbow & Sealing Plate Assembly
- 1 x 'O'-Ring Seal
- 1 x Tube of Silicone Sealant

The flue may exit from the rear, right or left side of the boiler. The termination point is angled, and can be rotated to enable the combustion fumes to be directed away from areas where they could cause a nuisance.

FITTING INSTRUCTIONS

- 1) Decide which direction the flue is to be pointed. Remove the top panel and using the nuts provided, fit the elbow/sealing plate assembly (**item 1**) onto the rubber gasket on top of the boiler via the 4 x studs, ensuring that the open end is pointed in the direction required.
- 2) Fit the 'o'-ring seal (**item 2**) into the groove on the flue terminal (**item 3**), ensuring that the flat, ribbed face is to the inside.
- 3) Smear a thin bead of silicone sealant (supplied) around the 'o'-ring seal and slide the terminal into the elbow from the outside of the boiler casing, being careful to ensure that the 'o'-ring remains in place. The rotation of the terminal should be decided before applying the silicone sealant.
- 4) Place the terminal in the desired position and angle of rotation. Ensure that a minimum distance of 50mm is kept from the termination point to the face of the boiler casing.
- 5) Slide one of the sealing rubbers (**item 4**) over the terminal to meet the boiler casing, ensuring the holes line up with those in the casing.
- 6) Fit the collar plate (**item 6**) over the flue terminal and secure to the boiler casing with the screws provided, clamping the sealing rubber firmly in place.
- 7) Blank off the 2 x unused flue openings on the boiler casings with the remaining sealing rubbers and blanking plates (**item 5**).
- 8) Replace the top casing and fit the terminal guard (**item 7**) over the flue, securing in position with the screws provided.

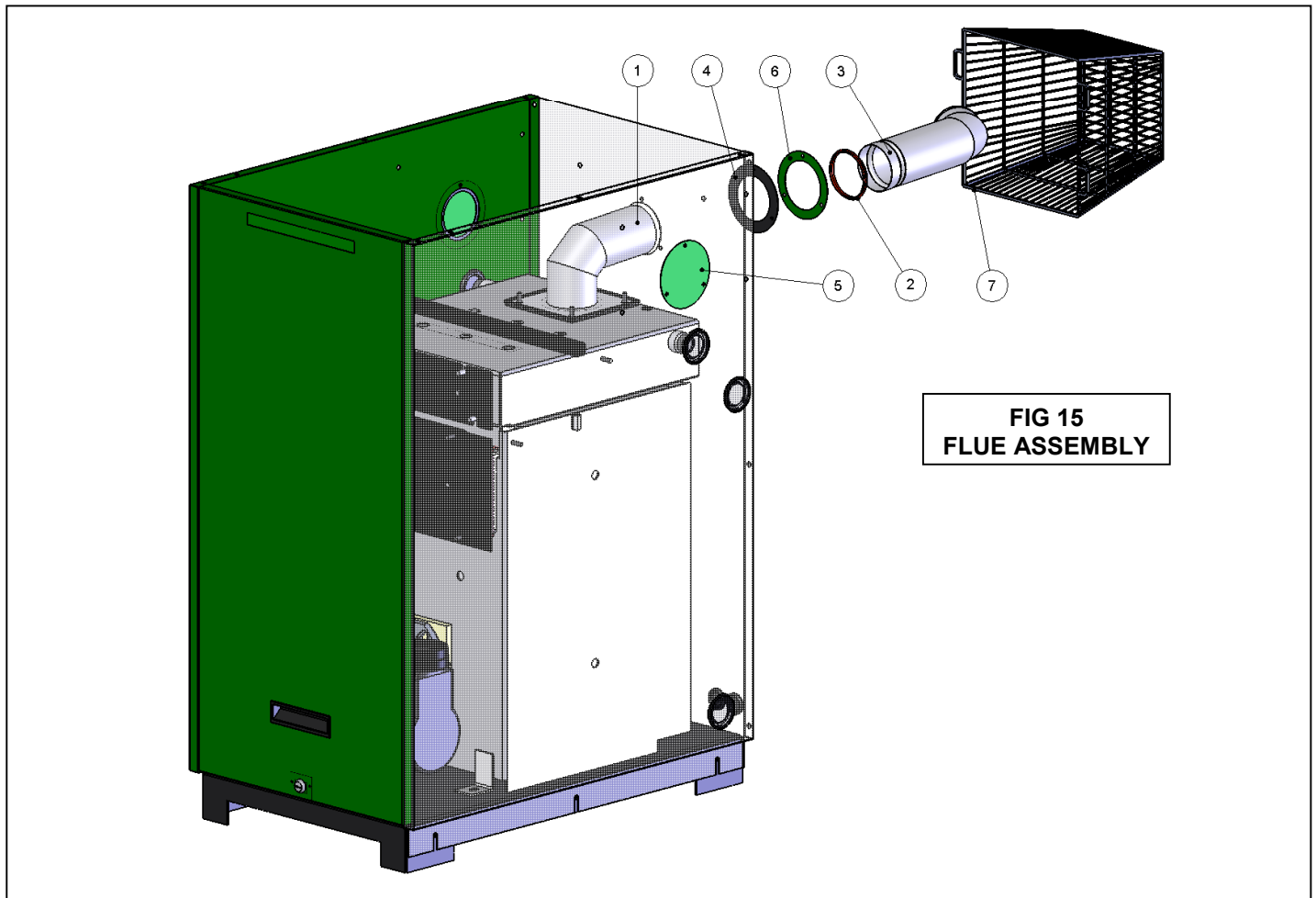

FIG 15
FLUE ASSEMBLY

7. COMMISSIONING

The boiler/burner **MUST** be commissioned by a qualified technician, preferably OFTEC trained and registered.

It is the responsibility of the installer to ensure the boiler is properly commissioned, failure to do so will make the boiler's guarantee and any extended warranty null and void.

Although all burners are factory tested before despatch, they will usually need further air adjustment to achieve the readings indicated in 'Burner detail leaflet' because of site variations in flue draught and back pressure.

Procedure

1. Switch off electrical supply to the boiler.
2. Ensure boiler is full of water and all valves are open.
3. Remove flue-cover and check that flue-baffles are correctly positioned (See Fig 20 for baffle arrangement).
4. Disconnect oil hose from burner, open shut-off valve and run off a quantity of oil into a container to check for a clean air free supply then reconnect hose. (This applies to single pipe gravity system only).
5. Check that the time-switch (if fitted) is in the ON position and room and boiler thermostats are calling for heat.
6. Switch on electrical supply and the burner should start.

Note: The burner may lock-out on first firing due to air in the pump, if this happens, wait about a minute before pressing reset button to restart burner. If a further lock-out occurs, the air should be bled from the pump pressure gauge connection.

7. Start and stop the burner two or three times until the flame cuts off sharply - this indicates any remaining air has been dispersed.
8. Allow the burner to run for about 15 minutes, then take a CO₂ reading through the sampling hole in flue-cover. Compare the reading with that given under 'Burner Settings' and adjust the air setting if necessary to achieve the required CO₂%. Also, check the smoke and flue gas temperature.
9. If the system is not going to be put into immediate operation, the fuel supply and electricity supply should be isolated.
If there is a possibility that the boiler will not be running during freezing conditions, the system should be drained down.

Handing Over

After completing the boiler installation, the installer should make a thorough check of the system to ensure it is completely satisfactory and demonstrate to the user the operation of the boiler and any system controls.

All instructions should be handed to the user for retention and advice regarding the need for annual servicing.

8. SERVICING

IMPORTANT: ISOLATE ELECTRICAL SUPPLY TO THE BOILER BEFORE SERVICING

To maintain the boiler's high thermal efficiency and ensure reliable operation, it should be serviced annually by a qualified and registered OFTEC engineer. Electrical work should be carried out by a qualified engineer. A CD/11 servicing and commissioning form should be completed and left with the appliance on-site.

If the boiler is used to provide central heating and hot water all year round, the best time for the annual service is just before the start of the heating season.

Oil tank

Open tank drain-cock to draw off any accumulated water and sludge.

Line filters

Turn off oil supply and remove filter bowl. Wash filter element clean with kerosene.

Important

Before commencing with service work on either the boiler or the fuel supply please read the health and safety information.

Before servicing the boiler carry out the following checks.

1. Ensure the air inlets on the flue terminal are not blocked or obstructed.
2. Check to ensure external controls are working correctly.
3. Check ventilation openings are not obstructed and are adequate for the size of the boiler.
4. Inspect all connections to boiler to ensure they are sound, remake any joints that are showing signs of leakage.
5. Inspect flexible oil supply lines and replace where necessary.

Condensate Unit & Trap

The condensate unit and trap should be inspected as part of the annual service schedule. Remove the access cover from the top of the condensate unit and clean all deposits from within. Ensure there are no blockages within the condensate pipework and the 'U' trap itself. When complete, recheck the integrity of the pipework joints by pouring a small amount of water into the condensate unit and looking for leaks. Some water should be retained within the 'U' trap.

Casing

Clean with a damp cloth. Check for signs of corrosion, apply a suitable protective material if necessary.

Servicing the Boiler

- 1 Remove the flexible air supply hose from the flue kit to the burner.
- 2 Remove burner ensure that if flexible oil supply hose has to be disconnected that there is no spillage of oil.
- 3 Remove both flue-cleaning covers from front of boiler lift out flue baffles from boiler then slide baffles out of condensing unit.
- 4 Brush all deposits from the flue baffles and clean the internal surfaces of the boiler.
- 5 Remove any flue deposits from the combustion chamber floor using a vacuum cleaner.
- 6 Clean the flue way surfaces of the condenser unit removing any deposits.
- 7 Check flue sealing gasket.
- 8 Inspect flue cleaning door seals and replace if necessary.
- 9 Replace the nozzle.
- 10 Check to ensure that the condense drain is working and not blocked by pouring a small amount of water into condenser unit and checking to see that water discharges from condense port.
- 11 Replace flue baffles in correct arrangement (see diagram) Refit both flue covers securing in position making gas tight seal using washers and wing nuts previously removed.
- 12 Check condensate trap to ensure the outlet is not obstructed.
- 13 Refit the burner securing the air hose in position using the clips provided.
- 14 Reconnect the flexible oil line to the burner (if removed).
- 15 Turn on oil supply, switch on electricity ensure system is calling for heat, boiler should now fire.
- 16 Finally check the combustion settings to those given under Burner Settings and make any adjustments where necessary.

FIG. 16 – BAFFLE ARRANGEMENTS

**IMPORTANT:
FAILURE TO ENSURE THE CORRECT PLACEMENT OF BAFFLES WILL
RESULT IN THE INCORRECT OPERATION OF THE BOILER,
INVALIDATING THE APPLIANCE WARRANTY.**

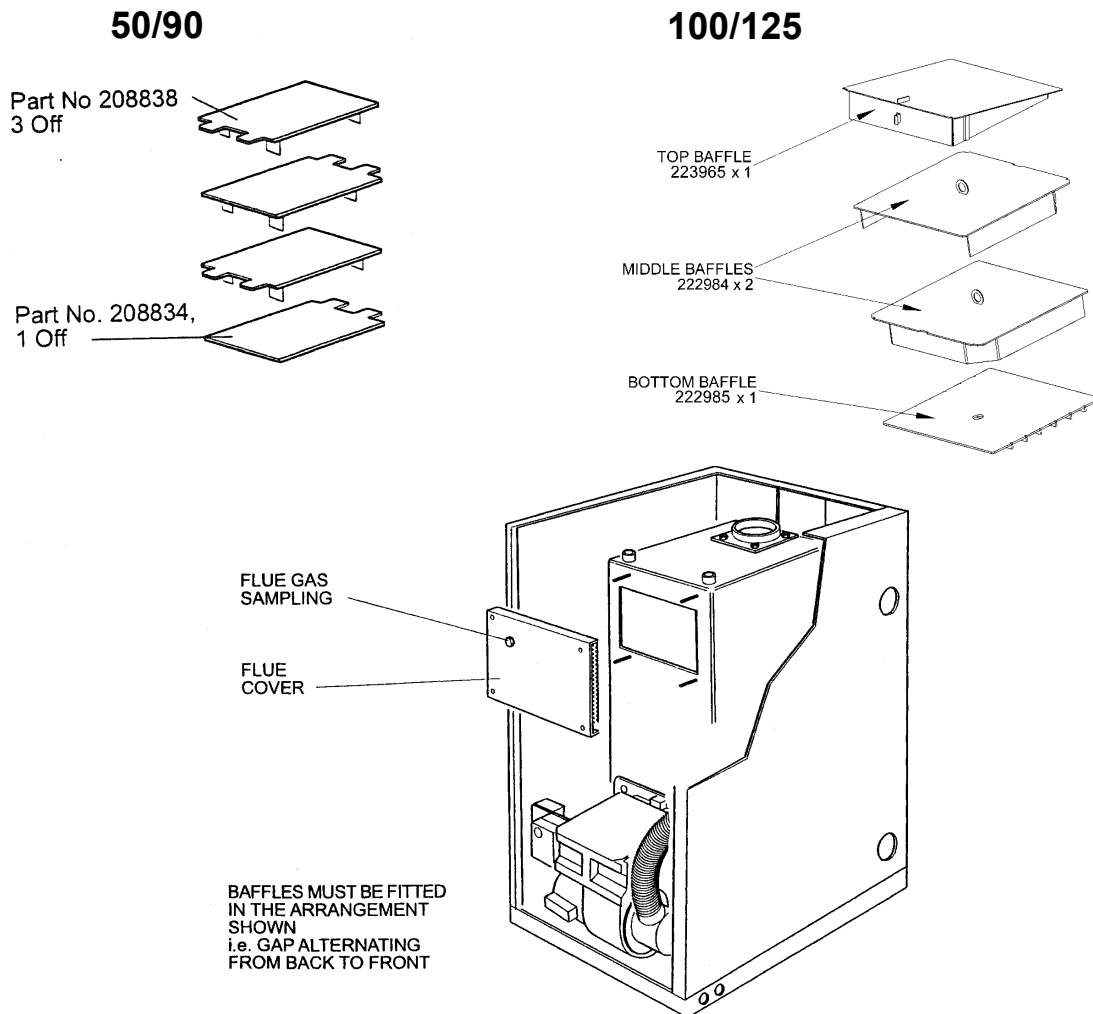

9. FAULT-FINDING

BURNER FAULT-FINDING

ELECTRICAL SAFETY - before making any electrical checks, switch off the mains supply to the boiler

FAULT	POSSIBLE CAUSE	ACTION
BURNER WILL NOT START	Control box locked out	Press orange reset button on front of burner. NB: ONLY TRY TWICE
	High limit stat tripped	Press red reset button (under control panel) and check function of boiler stat
	System controls satisfied	Ensure all controls are calling for heat
	Fuse blown	Fit new fuse (5A). If problem persists, check for short circuit in wiring
	Motor or pump seized	Check for rotation, replace as necessary
BURNER STARTS BUT FLAME NOT ESTABLISHED	No oil supply	Check oil level in tank, check oil supply for adequate flow
	Photocell not seeing flame	Clean photocell, ensure it is fully inserted
	Air trapped in pump	Bleed excess air via tapping on oil pump
	Solenoid valve faulty	Check coil for continuity, replace as necessary
	Nozzle blocked	Replace nozzle with one of same specification (see burner leaflet)
	Electrodes incorrectly set	Reset gap and position to settings shown in burner leaflet
	Electrode insulator cracked	Replace as necessary
	Ignition transformer or leads faulty	Check for spark, check condition of HT leads, replace as necessary
Low oil pressure	Check pump pressure and adjust to settings shown in burner leaflet	
FLAME ESTABLISHED BUT BURNER LOCKS OUT AFTER A FEW SECONDS	Oil contaminated with water	Run off oil at burner until free of water and drain condensation from tank
	Oil filter partially blocked	Wash filter clean with kerosene
	Photocell faulty	Clean photocell, ensure it is fully inserted, check for damage. Replace as necessary
	Low oil pressure	Check pump pressure and adjust to settings shown in burner leaflet

BURNER FAULT-FINDING (cont.)

ELECTRICAL SAFETY - before making any electrical checks, switch off the mains supply to the boiler

FAULT	POSSIBLE CAUSE	ACTION
MORNING START LOCKOUT	Faulty non-return valve or air leak in two-pipe system	Replace non-return valve, cure leak
	Low voltage to appliance	Check with local electricity board
	Combustion settings incorrect	Check combustion under normal running conditions, check against settings shown in burner leaflet
	Oil level in tank falling below burner	Raise tank or fir two-pipe system
DELAYED IGNITION (BURNER PULSATES ON STARTUP)	Nozzle partially blocked	Replace nozzle with one of same specification (see burner leaflet)
	Low oil pressure	Check pump pressure and adjust to settings shown in burner leaflet
	Flue blocked or damaged	Check flue and rectify/replace as necessary
	Fan slipping on shaft	Check fan and retighten/replace as necessary
	Pump coupling loose or worn	Check fan and rectify/replace as necessary
BURNER STARTS VIOLENTLY	Delayed ignition	Reset electrode gap and position to settings shown in burner leaflet
		Check electrodes for damage, replace as necessary
		Check condition of HT leads, replace as necessary
BURNER REPEATEDLY ATTEMPTS TO FIRE (balanced flue only)	Exhaust gas in combustion air	Remove air hose from boiler end of flue, leaving burner end in place. If burner starts normally, check flue for breakdown of seals and repair/replace as necessary
		If indeterminate, leaving hose attached, pierce a small hole in air hose and use flue gas analyser to check for carbon dioxide. If more than trace elements present, check flue for breakdown of seals and repair/replace as necessary
COMBUSTION FUMES SMELL	Baffle access cover not secure	Tighten wing nuts, securing door in position
	Baffle access cover seal damaged	Replace seal as necessary
	Burner incorrectly fitted, or fixing gasket damaged	Check burner fixing gasket, replace as necessary. Tighten burner mounting nuts
	Flue gasket damaged	Check gasket, replace as necessary. Tighten flue mounting nuts

SPARES

Item	Description	50/90	Qty	100/125	Qty
1	Boiler Body	222421	1	223971	1
2	Right Side Panel Assembly	223496	1	223506	1
3	Left Side Panel Assembly	223495	1	223505	1
4	Top Panel	210952	1	221712	1
5	Front Door	223493	1	223503	1
6	Back Panel	223497	1	223507	1
7	Condensing Unit	223880	1	223880	1
8	Boiler Control Thermostat	206896	1	206896	1
9	High-Limit Thermostat	206892	1	206892	1
10	Frost Thermostat	209735	1	209735	1
11	Control Box Assembly	210799	1	210799	1
12	Flue Assembly	223470	1	223470	1
13	Flue Sealing Gasket	223071	1	223071	1
14	Flue Gasket	223787	1	223787	1
14a	Top Baffle ¹	208838	3	223965	1
15	Middle Baffle ¹	-	-	222984	2
16	Bottom Baffle ¹	208834	1	223336	1
17	Baffle Access Cover	208803	1	208803	1
18	Burner	223868	1	223928	1
19	Burner Cover	223444	1	223444	1
20	Burner Cover Plate	223447	1	223447	1
21	Flexible Oil Line ²	207019	1	207019	1
22	Acoustic Hose	209491	1	209491	1
23	Burner Mounting Flange	223118	1	223118	1
24	Burner Mounting Gasket	223108	1	223108	1
25	Condensate Pipework	223939	1	223939	1
26	Return Pipework Assembly	222973	1	223987	1
27	Drain Cock	99592	1	99592	1
28	Condensate Unit Access Cover	223898	1	223898	1
29	Condensate Unit Access Cover Gasket	223899	1	223899	1
30	Air Box Spigot	223863	1	223969	1
31	Automatic Air Vent	207296	1	207296	1
32	Flue Seal Clamping Collar	223844	1	223844	1
33	Flue Sealing Rubber	223853	3	223853	3
34	Blanking Plate	223842	2	223842	2
35	Casing Grommet	210787	6	210787	6
36	Terminal Guard	223479	1	223479	1

¹ See Fig. 16 (page 19) for baffle configurations.

² See burner details leaflet for further information.



By appointment to H.M. Queen Elizabeth
The Queen Mother
Manufacturers of Domestic Boilers



TRIANCO HEATING PRODUCTS LTD
Thornccliffe, Chapeltown
Sheffield S35 2PH
Tel: (0114) 257 2300
Fax: (0114) 257 1419
www.trianco.co.uk



© Trianco Limited, Copyright in this brochure and the drawings or illustrations contained in it is vested in Trianco Limited and neither the brochure or any part thereof may be reproduced without prior written consent.

Trianco Limited's policy is one of continuous research and development. This may necessitate alterations to this specification.